

Optocouplers R600 range

Table of contents

Optocouplers R600 range	
Product group picture	5/63
Table of contents	5/64
Selection	5/65
Ordering details	5/67
Connection diagrams	5/68
Technical data	5/69

Optocouplers R600 range Selection

Type	Order number
OBIC 0100 5-12VDC	1SNA 645 047 R0000
OBIC 0100 5-12VDC	1SNA 645 547 R0200
OBIC 0100 24VDC	1SNA 645 021 R2600
OBIC 0100 24VDC	1SNA 645 521 R2000
OBIC 0100 48-60VAC/DC	1SNA 645 049 R1200
OBIC 0100 48-60VAC/DC	1SNA 645 549 R1400
OBIC 0100 115-230VAC/DC	1SNA 645 022 R2700
OBIC 0100 115-230VAC/DC	1SNA 645 522 R2100
OBOC 1000-5-12VDC	1SNA 645 050 R1700
OBOC 1000-5-12VDC	1SNA 645 550 R1100
OBOC 1000-24VDC	1SNA 645 051 R0400
OBOC 1500-24VAC/DC	1SNA 645 025 R2200
OBOC 5000-24VDC	1SNA 645 024 R2100
OBOC 1000-24VDC	1SNA 645 551 R0600
OBOC 1500-24VAC/DC	1SNA 645 525 R2400
OBOC 5000-24VDC	1SNA 645 524 R2300
OBOC 1000-48-60VAC/DC	1SNA 645 053 R0600
OBOC 1000-48-60VAC/DC	1SNA 645 553 R0000
OBOC 1000-115VAC/DC	1SNA 645 054 R0700
OBOC 5000-115VAC/DC	1SNA 645 058 R1300
OBOC 1000-115VAC/DC	1SNA 645 554 R0100
OBOC 5000-115VAC/DC	1SNA 645 558 R1500
OBOC 1000-230VAC/DC	1SNA 645 026 R2300
OBOC 5000-230VAC/DC	1SNA 645 059 R1400
OBOC 1000-230VAC/DC	1SNA 645 526 R2500
OBOC 5000-230VAC/DC	1SNA 645 559 R1600
OBOA 1000-24VDC	1SNA 645 027 R2400
OBOA 2000-24VDC	1SNA 645 029 R0600
OBOA 1000-24VDC	1SNA 645 527 R2600
OBOA 2000-24VDC	1SNA 645 529 R0000

Input voltage																				
5 - 12 V DC	■	■																		
24 V DC			■	■																
48 - 60 V DC					■	■														
115 - 230 V DC							■	■												
115 V DC																				
230 V DC									■	■										
24 V AC																				
48 - 60 V AC																				
115-230 V AC																				
115 V AC																				
230 V AC																				

Output rating																				
100 mA	■	■	■	■	■	■	■	■												
2 A																				
5 A																				
1 A																				

Output voltage																				
58 V DC	■	■	■	■	■	■	■	■	■	■	■	■	■	■	■	■	■	■	■	■
400 V AC																				

Terminal type																				
Screw	■		■		■		■		■		■		■		■		■		■	
Spring		■		■		■		■		■		■		■		■		■		■

Optocouplers R600 range Selection

OBOA 1000-48-60VAC/DC	1SNA 645 061 R0600
OBROA 1000-48-60VAC/DC	1SNA 645 561 R0000
OBOA 1000-115VAC/DC	1SNA 645 062 R0700
OBROA 1000-115VAC/DC	1SNA 645 562 R0100
OBOA 1000-230VAC/DC	1SNA 645 028 R0500
OBROA 1000-230VAC/DC	1SNA 645 528 R0700

Optocouplers R600 range

Ordering details



2CDC291 001 R0013

5

R600 Optocoupler	Type	Order code	Price	Pkg qty	Weight (1 pce) kg (lb)
Optocoupler module 100 mA/DC	OBIC 0100-5-12VDC	1SNA645047R0000		10	0.02 (0.44)
	OBIC 0100-24VDC	1SNA645021R2600			
	OBIC 0100-48-60VAC/DC	1SNA645049R1200			
Optocoupler module 100 mA/DC	OBIC 0100-115-230VAC/DC	1SNA645022R2700		10	0.02 (0.44)
	OBRIC 0100-5-12VDC	1SNA645547R0200			
	OBRIC 0100-24VDC	1SNA645521R2000			
Optocoupler module 2 A/DC	OBRIC 0100-48-60VAC/DC	1SNA645549R1400		10	0.02 (0.44)
	OBRIC 0100-115-230VAC/DC	1SNA645522R2100			
	OBOC 1000-5-12VDC	1SNA645050R1700			
Optocoupler module 2 A/DC	OBOC 1000-24VDC	1SNA645051R0400		10	0.02 (0.44)
	OBOC 1500-24VAC/DC	1SNA645025R2200			
	OBOC 1000-48-60VAC/DC	1SNA645053R0600			
	OBOC 1000-115VAC/DC	1SNA645054R0700			
	OBOC 1000-230VAC/DC	1SNA645026R2300			
Optocoupler module 2 A/DC	OBROC 1000-5-12VDC	1SNA645550R1100		10	0.02 (0.44)
	OBROC 1000-24VDC	1SNA645551R0600			
	OBROC 1500-24VAC/DC	1SNA645525R2400			
	OBROC 1000-48-60VAC/DC	1SNA645553R0000			
	OBROC 1000-115VAC/DC	1SNA645554R0100			
Optocoupler module 5 A/DC	OBROC 1000-230VAC/DC	1SNA645526R2500		10	0.02 (0.44)
	OBOC 5000-24VDC	1SNA645024R2100			
	OBOC 5000-115VAC/DC	1SNA645058R1300			
Optocoupler module 5 A/DC	OBOC 5000-230VAC/DC	1SNA645059R1400		10	0.02 (0.44)
	OBROC 5000-24VDC	1SNA645524R2300			
	OBROC 5000-115VAC/DC	1SNA645558R1500			
Optocoupler module 1 A/AC 6 mm spacing	OBROC 5000-230VAC/DC	1SNA645559R1600		10	0.03 (0.066)
	OBOA 1000-24VDC	1SNA645027R2400			
	OBOA 1000-48-60VAC/DC	1SNA645061R0600			
Optocoupler module 2 A/AC 12 mm spacing	OBOA 1000-115VAC/DC	1SNA645062R0700		5	0.03 (0.066)
	OBOA 1000-230VAC/DC	1SNA645028R0500			
	OBOA 2000-24VDC	1SNA645029R0600			
Optocoupler module 1 A/AC 6 mm spacing	OBROA 1000-24VDC	1SNA645527R2600		10	0.03 (0.066)
	OBROA 1000-48-60VAC/DC	1SNA645561R0000			
	OBROA 1000-115VAC/DC	1SNA645562R0100			
	OBROA 1000-230VAC/DC	1SNA645528R0700			
Optocoupler module 2 A/AC 12 mm spacing	OBROA 2000-24VDC	1SNA645529R0000		5	0.03 (0.066)

Accessories	Type	Order code	Price	Pkg qty	Weight (1 pce) kg (lb)
End section	BADH V0	1SNA116900R2700		50	
	BADL V0	1SNA399903R0200		50	
	BAM2 V0	1SNA399967R0100		50	
Separator end section	SC 612	1SNA290474R0200		10	
Divisible shunt 10 poles	BJ 612-10	1SNA290488R0100		10	
Divisible shunt 20 poles	BJ 612-20	1SNA206754R0000		10	
Screw clamp distribution block sp. 12 mm	D4/12-3-3	1SNA645031R2000		5	
Spring clamp distribution block sp. 12 mm	D4/12-3R-3R	1SNA645531R2200		5	
Test plug DIA. 2 mm	FC2	1SNA645531R2200		10	
Marking method	RC65 / RC610	see marking			

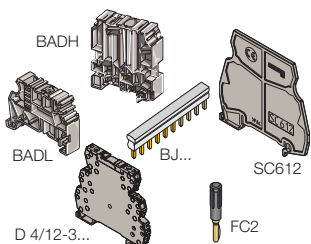

Optocouplers R600 range

Connection diagrams

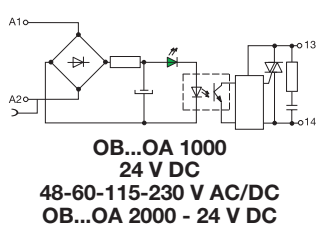
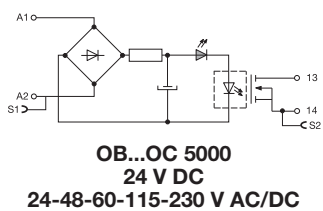
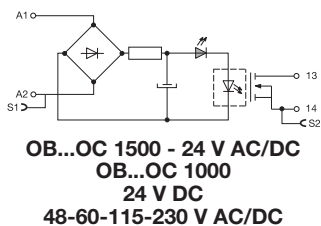
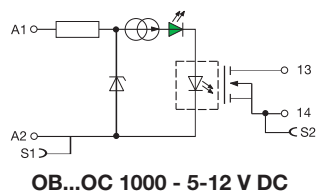
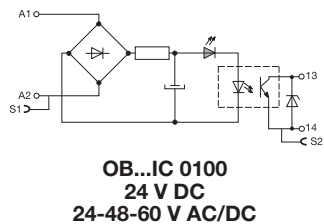
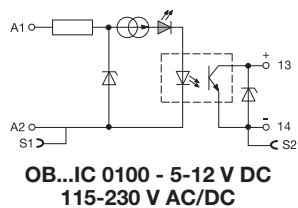





Optocouplers R600 range

Technical data

Technical data

Optocoupler : 5 to 58 V DC output / 100 mA - 6 mm 0.236" spacing

5

		OB...IC 0100					
Relay characteristics coil							
Input voltage: +20%, -15% on DC ; 10%, -10% on AC	5 V DC - 12 V DC	24 V DC		48 V AC/DC	60 V AC/DC	115 V AC/DC	230 V AC/DC
Frequency				50 / 60 Hz			
Input current AC/DC	5 mA	9 mA	4 mA	4 mA	5 mA	7 mA / 16 mA	11.5 mA / 25 mA
Pull-in voltage at Is=100%	4 V		15 V	25 V	60 V AC / 70 V DC		
Switching time C / O	10 µs / 500 µs						
Operating frequency	1000 Hz			5 ms / 20 ms		5 ms / 15 ms	
Permissible leakage current				20 Hz			
Output	0.9 mA	1 mA		0.9 mA	1.6 mA		
Output voltage	4.5 to 58 V DC						
Output current min.	1 mA						
Output current max.	100 mA						
Output leakage current at U _{max}	< 50 µA						
Residual voltage at I max and U rated	typical	1 V					
	max	1.3 V					
Frequency on inductive load							
Isolation Input / Output	input / Output	2500 V RMS					
Temperature	storage	-40...+80 °C					
	operating	-20...+70 °C ¹⁾					
Other characteristics		Screw clamp			Spring clamp		
Body material	grey	UL 94 V0					
Wire size	Solid wire	0.2 - 4 mm ² (24-12 AWG)			0.2-2.5 mm ² (24-12 AWG)		
	Stranded wire	0.22 - 2.5 mm ² (24-12 AWG)					
Rated wire size	2.5 mm ² (12 AWG)						
Wire stripping length	9 mm (0.354 in)						
Recommended screwdriver	3.5 mm (0.137 in)						
Protection	IP20 NEMA1						
Recommended torque	0.4-0.6 Nm (3.5-5.3 lb.in)						
Approvals	c  US (pending for 12 V DC) ,  (pending) ,  , LRS , 						
Reference standards	CEI 947-7-1 / CEI 947-1 / CEI 1131-2 (in relevant parts) / CEI 60664-1 / CEM : IEC 1000-4-2, 3, 4, 5, 6.						

¹⁾ Over 55°C, blocks have to be mounted on horizontal rail with 10 mm spacing between each block. For vertical rail mounting use temperature is 15°C less decreased.

Dimensional drawings

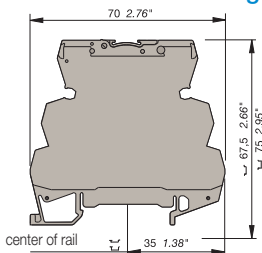

Screw clamp module

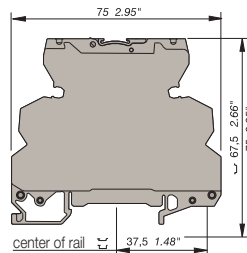





Spring clamp module

Optocouplers R600 range

Technical data

Technical data

Optocoupler : 5 to 58 V DC output / 2 A - 6 mm 0.236" spacing

	OB...OC 0100		OB..OC 1500	OB...OC 1000				
Relay characteristics coil								
Input voltage: +20%, -15% on DC ; 10%, -10% on AC	5 V DC - 12 V DC		24 V DC	24 V AC/DC	48 V AC/DC	60 V AC/DC	115 V AC/DC	230 V AC/DC
Frequency			50 / 60 Hz					
Input current	5 mA	9 mA	4 mA	6.3 mA	4 mA	5.1 mA	4.2 mA	4 mA
Pull-in voltage at Is=100%	4 V		15 V	15 V	27 V		50 V	80 V
Switching time C / O	15 μ s / 250 μ s		30 μ s / 400 μ s	1 ms / 7 ms	5 ms / 20 ms		500 μ s / 10 ms	1 ms / 15 ms
Operating frequency	2000 Hz		1000 Hz	60 Hz	20 Hz			
Permissible leakage current	1 mA		0.8 mA	0.9 mA	1 mA		0.3 mA	
Output								
Output voltage	4.5 to 58 V DC							
Output current min.	1 mA							
Output current max.	2 A							
Output leakage current at U _{max}	< 50 μ A							
Residual voltage at I max and U rated	typical		0.1 V					
	max		0.5 V					
Frequency on inductive load								
Isolation Input / Output	input / Output	2500 V RMS						
Temperature	storage		-40...+80 °C					
	operating		-20...+70 °C ¹⁾					
Other characteristics			Screw clamp			Spring clamp		
Body material	grey	UL 94 V0						
Wire size	Solid wire	0.2 - 4 mm ² (24-12 AWG)			0.2-2.5 mm ² (24-12 AWG)			
	Stranded wire	0.22 - 2.5 mm ² (24-12 AWG)						
Rated wire size	2.5 mm ² (12 AWG)							
Wire stripping length	9 mm (0.354 in)							
Recommended screwdriver	3.5 mm (0.137 in)							
Protection	IP20 NEMA1							
Recommended torque	0.4-0.6 Nm (3.5-5.3 lb.in)							
Approvals	c  us (pending for 12 V DC),  (pending),  , LRS, 							
Reference standards	CEI 947-7-1 / CEI 947-1 / CEI 1131-2 (in relevant parts) / CEI 60664-1 / CEM : IEC 1000-4-2, 3, 4, 5, 6.							

¹⁾ Over 55°C, blocks have to be mounted on horizontal rail with 10 mm spacing between each block. For vertical rail mounting use temperature is 15°C less decreased.

Dimensional drawings

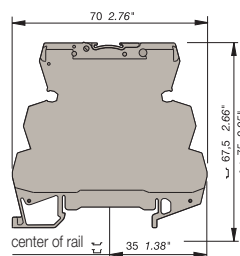

Screw clamp module

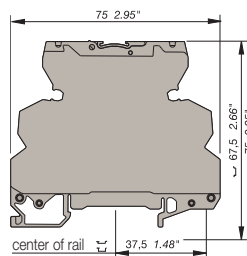

Spring clamp module

Optocouplers R600 range

Technical data

Technical data



Optocoupler : 5 to 58 V DC output / 5 A - 6 mm 0.236" spacing

OB... OC 5000

Input			
Input voltage	24 V DC	115 V AC/DC	230 V AC/DC
Frequency		50 / 60 Hz	50 / 60 Hz
Input current	5.4 mA	4.2 mA	4 mA
Pull-in voltage at Is=100%	12 V	50 V	80 V
Switching time C / O	30 µs / 400 µs	500 µs / 10 ms	1ms / 15 ms
Operating frequency	1000 Hz	50 Hz	35 Hz
Permissible leakage current	0.8 mA	0.3 mA	0.3 mA

Output	
Output voltage	4.5 - 58 V DC
Output current min.	25 mA
Output current max.	5 A
Output leakage current at U _{max}	< 0.50 mA
Residual voltage at I max and U rated	typical 1 V
	max 1.6 V
Frequency on inductive load	See Note 1
Isolation Input / Output	input / Output 2500 V RMS

Temperature	
Ambient temperature	storage : -40...+80 °C
	operating : See derating curve

Other characteristics	
Body material	grey UL 94 V0
Wire size	Solid wire 0.2 - 4 mm ² (24-12 AWG)
	Stranded wire 0.22 - 2.5 mm ² (24-12 AWG)
Rated wire size	2.5 mm ² (12 AWG)
Wire stripping length	10 mm (0.394 in)
Recommended screwdriver	3.5 mm (0.137 in)
Protection	IP20 NEMA1
Recommended torque	0.4-0.6 Nm (3.5-5.3 lb.in)
Approvals	 (pending), 
Reference standards	CEI 947-7-1 / CEI 947-1 / CEI 1131-2 (in relevant parts) / CEI 60664-1 / CEM : IEC 1000-4-2, 3, 4, 5, 6.

Dimensional drawings

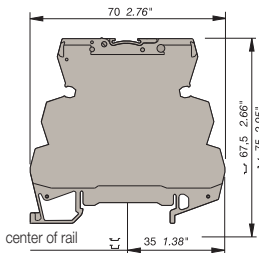

Screw clamp module

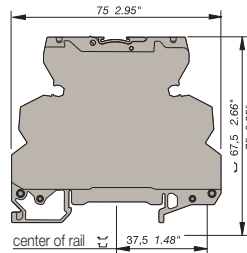



Spring clamp module

Optocouplers R600 range

Technical data

Technical data

Optocoupler : 24 to 400 V AC output / 2 A max. - 6 mm or 12 mm spacing

	OB...OA 1000					OB...OA 2000	
Relay characteristics coil							
Input voltage: +20%, -15% on DC ; 10%, -10% on AC	24 V DC	48 V AC/DC	60 V AC/DC	115 V AC/DC	230 V AC/DC	24 V DC	
Frequency		50/60 Hz					
Input current	3.6 mA	4.3 mA	5.5 mA	4.15 mA	4.6 mA	3.6 mA	
Pull-in voltage at Is=100%	14 V	15 V	18 V	60 V	135 V	14 V	
Switching time C / O	150 μs / 1 ms	3 ms / 30 ms		2.2 ms / 18 ms	2.5 ms / 25 ms	150 μs / 1 ms	
Operating frequency	500 Hz	20 Hz		25 Hz	20 Hz	500 Hz	
Permissible leakage current	1 mA						
Output							
Output voltage	24-400 V AC						
Frequency	50/60 Hz						
Output current min.	25 mA						
Output current max.	1 A						2 A
Output leakage current at U _{max}	< 0.50 mA						
Residual voltage at I _{max} and U rated	typical	1 V					
	max	1.6 V					
Frequency on inductive load							
Isolation Input / Output	input / Output	2500 V RMS					
Temperature	storage	-40...+80 °C					
	operating	-20...+70 °C ¹⁾					
Other characteristics		Screw clamp			Spring clamp		
Body material	grey	UL 94 V0					
Wire size	Solid wire	0.2 - 4 mm ² (24-12 AWG)			0.2-2.5 mm ² (24-12 AWG)		
	Stranded wire	0.22 - 2.5 mm ² (24-12 AWG)					
Rated wire size		2.5 mm ² (12 AWG)					
Wire stripping length		9 mm (0.354 in)					
Recommended screwdriver		3.5 mm (0.137 in)					
Protection		IP20 NEMA1					
Recommended torque		0.4-0.6 Nm (3.5-5.3 lb.in)					
Approvals		 us (pending for 12 V DC) ,  (pending),  , LRS , 					
Reference standards		CEI 947-7-1 / CEI 947-1 / CEI 1131-2 (in relevant parts) / CEI 60664-1 / CEM : IEC 1000-4-2, 3, 4, 5, 6.					

¹⁾ Over 55°C, blocks have to be mounted on horizontal rail with 10 mm spacing between each block. For vertical rail mounting use temperature is 15°C less decreased.

Dimensional drawings

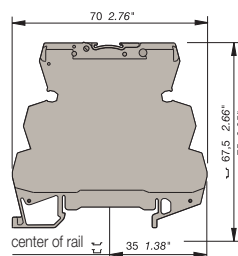

Screw clamp module

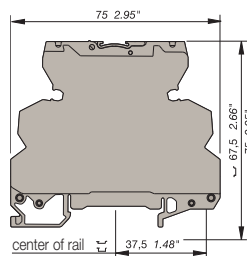

Spring clamp module

Terminal blocks component holder

Base for pluggable plug
R500 Series

DIN 3

End stop		th. 9 mm	BADL	V0	1SNA 399 903 R0200
End stop		th. 9,1 mm	BAM	V2	1SNA 103 002 R2600
End stop		th. 9,1 mm	BAM V0	V0	1SNA 199 306 R0300
Rail		35 x 7,5 x 1	PR3.Z2		1SNA 174 300 R1700
Rail		35 x 15 x 2,3	PR4		1SNA 168 500 R1200
Rail		35 x 15 x 1,5	PR5		1SNA 168 700 R2200

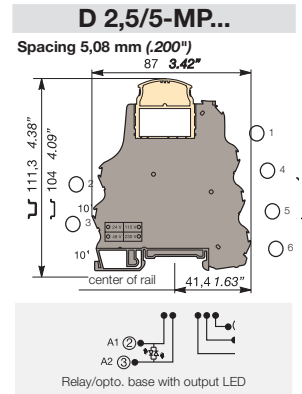
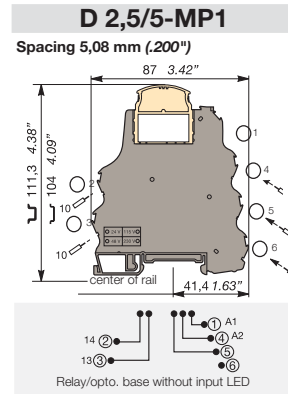
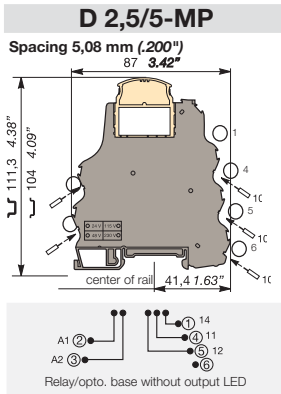

Observations

Terminal blocks are delivered without plugs.

Max. working temperature
version without LED : 100°C
version with LED : 85°C
Contact resistance : < 5 mΩ

Type	Part numbers	Type	Part numbers	Type	Part numbers
Grey V0	Order plugs separately	Grey V0	Order plugs separately	Grey V0	Order plugs separately
D 2,5/5-MP	1SNA607224R0100	D 2,5/5-MP1	1SNA607223R0000	D 2,5/5-MP-24VDC	1SNA607222R0700
				D 2,5/5-MP-24VAC/DC	1SNA607260R2100
				D 2,5/5-MP-48VAC/DC	1SNA607261R1600
				D 2,5/5-MP-110VAC	1SNA607266R1300
				D 2,5/5-MP-230VAC	1SNA607267R1400

Characteristics

Wire size	Compression clamp	Solid wire	IEC		UL/CSA pending	
			0,2-4 mm ²	24-12 AWG	0,2-4 mm ²	24-12 AWG
Voltage	Rated	Pulse	0,22-2,5 mm ²	24-12 AWG	0,22-2,5 mm ²	24-12 AWG
			320 V	300 V	320 V	300 V
Current	Rated	Pollution degree	4 kV		4 kV	
			3		3	
Wire size	Rated / Gauge	Solid wire	6 A	6 A	6 A	6 A
			2,5 mm ²	12 AWG	2,5 mm ²	12 AWG
Wire stripping length			10 mm / .394"		10 mm / .394"	
Recommended screwdriver			3,5 mm / .137"		3,5 mm / .137"	
Recommended torque			0,4-0,6 Nm / 3,5-5,3 lb.in		0,4-0,6 Nm / 3,5-5,3 lb.in	
Protection			IP 20 / NEMA1		IP 20 / NEMA1	

Accessories

	Type	Part numbers	Type	Part numbers	Type	Part numbers
1 Test device	DCB (1) blue	1SNA105028R2100	DCB (1) blue	1SNA105028R2100	DCB (1) blue	1SNA105028R2100
2 Test plug	FC2 DIA. 2	1SNA007865R2600	FC2 DIA. 2	1SNA007865R2600	FC2 DIA. 2	1SNA007865R2600
3 Relay plug 1 SPDT 10 mA/6 A 1 SPDT 1 mA/6 A	BNMS R24V-1 beige	1SNA031820R1400	BNMS R24V-1 beige	1SNA031820R1400	BNMS R24V-1 beige	1SNA031820R1400
4 Input optocoupler plug 5 V DC 24 V DC 24 V DC 48 V DC 125 V DC 24 V AC 48 V AC 115 V AC 230 V AC	BNMS N24V-3 red	1SNA031807R1400	BNMS T5V-1 white	1SNA031831R0300	BNMS N24V-3 red	1SNA031807R1400
5 Output optocoupler plug 24 V DC/100 mA 24 V DC/100 mA 24 V DC/2 A 24 V DC/2 A 24 V DC/1 A 24 V DC/1 A 24 V DC/1 A	BNMS P24V-3 red	1SNA031810R1200	BNMS T24V-1 white	1SNA031848R2400	BNMS P24V-3 red	1SNA031810R1200
5 Output optocoupler plug 5 V DC/100 mA 5 V DC/100 mA 48 V DC/100 mA 48 V DC/100 mA 5 V DC/2 A 5 V DC/2 A 5 V DC/1 A 5 V DC/1 A	BNMS N24V-1 red	1SNA031815R0300	BNMS T24V-2 white	1SNA031800R2100	BNMS N24V-1 red	1SNA031815R0300
7 Fuse plug 125 V/125 mA 125 V/500 mA 125 V/2 A 125 V/5 A 250 V/125 mA 250 V/2 A 250 V/5 A 125 V/125 mA 250 V/125 mA 125 V/2 A	BNMS N24V-2 beige	1SNA031847R1300	BNMS T48V-1 white	1SNA031801R1600	BNMS N24V-2 beige	1SNA031847R1300
8 Strap plug	BNMS N24V-2 red	1SNA031819R1700	BNMS T125V-1 white	1SNA031845R1100	BNMS N24V-2 red	1SNA031819R1700
9 Converter plug 0-20 mA/0-10 V 4-20 mA/2-10 V 0-20 mA/0-5 V 4-20 mA/1-5 V	BNMS A24V-4 black	1SNA031839R1300	BNMS T24V-1 yellow	1SNA031802R1700	BNMS A24V-4 black	1SNA031839R1300
10 Comb type jumper bar 10 poles	BNMS N5V-3 red	1SNA031806R1300	BNMS T48V-1 yellow	1SNA031803R1000	BNMS N5V-3 red	1SNA031806R1300
R See section on marking	BNMS P5V-3 red	1SNA031809R2600	BNMS T115V-1 yellow	1SNA031804R1100	BNMS P5V-3 red	1SNA031809R2600
	BNMS N48V-3 red	1SNA031808R2500	BNMS T230V-1 yellow	1SNA031805R1200	BNMS N48V-3 red	1SNA031808R2500
	BNMS P48V-3 red	1SNA031811R0700			BNMS P48V-3 red	1SNA031811R0700
	BNMS N5V-1 red	1SNA031812R0000	BNMS F125mA-1 grey	1SNA031821R0100	BNMS N5V-1 red	1SNA031812R0000
	BNMS P5V-1 red	1SNA031814R0200	BNMS F500mA-1 grey	1SNA031838R1200	BNMS P5V-1 red	1SNA031814R0200
	BNMS N5V-2 red	1SNA031816R0400	BNMS F2A-1 grey	1SNA031822R0200	BNMS N5V-2 red	1SNA031816R0400
	BNMS P5V-2 red	1SNA031818R1600	BNMS F5A-1 grey	1SNA031823R0300	BNMS P5V-2 red	1SNA031818R1600
	BNMS F125mA-1 grey	1SNA031821R0100	BNMS F125mA-2 grey	1SNA031824R0400	BNMS F125mA-1 grey	1SNA031821R0100
	BNMS F500mA-1 grey	1SNA031838R1200	BNMS F2A-2 grey	1SNA031825R0500	BNMS F500mA-1 grey	1SNA031838R1200
	BNMS F2A-1 grey	1SNA031822R0200	BNMS F5A-2 grey	1SNA031826R0600	BNMS F2A-1 grey	1SNA031822R0200
	BNMS F5A-1 grey	1SNA031823R0300			BNMS F5A-1 grey	1SNA031823R0300
	BNMS F125mA-2 grey	1SNA031824R0400	BNMS F2A-7 grey	1SNA031849R2500	BNMS F125mA-2 grey	1SNA031824R0400
	BNMS F2A-2 grey	1SNA031825R0500	BNMS ST1 grey	1SNA031829R1100	BNMS F2A-2 grey	1SNA031825R0500
	BNMS F5A-2 grey	1SNA031826R0600	BNMS ST2 grey	1SNA031830R1600	BNMS F5A-2 grey	1SNA031826R0600
	BNMS F125mA-3 grey	1SNA031827R0700			BNMS F125mA-3 grey	1SNA031827R0700
	BNMS F125mA-4 grey	1SNA031828R1000	BNMS F2A-1 grey	1SNA031822R0200	BNMS F125mA-4 grey	1SNA031828R1000
	BNMS F2A-7 grey	1SNA031849R2500	BNMS F5A-1 grey	1SNA031823R0300	BNMS F2A-7 grey	1SNA031849R2500
	BNMS ST1 grey	1SNA031829R1100	BNMS F125mA-2 grey	1SNA031824R0400	BNMS ST1 grey	1SNA031829R1100
	BNMS ST2 grey	1SNA031830R1600	BNMS F2A-2 grey	1SNA031825R0500	BNMS ST2 grey	1SNA031830R1600
	BNMS CAI/U-500 grey	1SNA031832R0400	BNMS F5A-2 grey	1SNA031826R0600	BNMS CAI/U-500 grey	1SNA031832R0400
	BNMS CAI/U-500 grey	1SNA031832R0400			BNMS CAI/U-500 grey	1SNA031832R0400
	BNMS CAI/U-250 grey	1SNA031833R0500	BNMS F125mA-1 grey	1SNA031821R0100	BNMS CAI/U-250 grey	1SNA031833R0500
	BNMS CAI/U-250 grey	1SNA031833R0500	BNMS F500mA-1 grey	1SNA031838R1200	BNMS CAI/U-250 grey	1SNA031833R0500
	PCMS V0 (2) RC 55	1SNA205523R2200	BNMS F2A-1 grey	1SNA031822R0200	PCMS V0 (2) RC 55	1SNA205523R2200
			BNMS F5A-1 grey	1SNA031823R0300		
			BNMS F125mA-2 grey	1SNA031824R0400		
			BNMS F2A-2 grey	1SNA031825R0500		
			BNMS F5A-2 grey	1SNA031826R0600		
			BNMS F125mA-3 grey	1SNA031827R0700		
			BNMS F125mA-4 grey	1SNA031828R1000		

(1) Solely on the top stage. (2) Comb type jumper bar from 2 to 22 poles, see accessories.

Transistor output optocoupler plugs

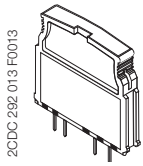

100 mA output optocoupler 5 V DC

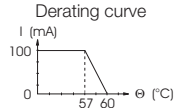
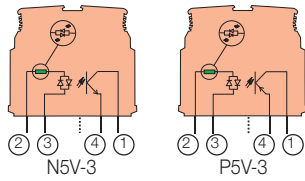

100 mA output optocoupler 24 V DC

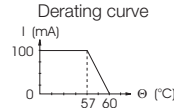
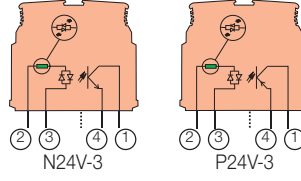

100 mA output optocoupler 48 V DC

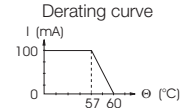
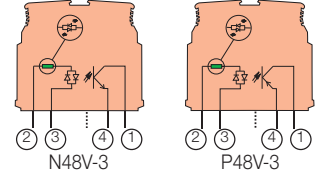

Part numbers	Type	P/N	Type	P/N	Type	P/N
	BNMS N5V-3	1SNA031806R1300	BNMS N24V-3	1SNA031807R1400	BNMS N48V-3	1SNA031808R2500
	BNMS P5V-3	1SNA031809R2600	BNMS P24V-3	1SNA031810R1200	BNMS P48V-3	1SNA031811R0700
Characteristics						
INPUT						
Voltage	4,5 V to 5,5 V DC		20,4 V to 28,8 V DC		40,8 V to 57,6 V DC	
Max. current	8,5 mA		4,8 mA		3,9 mA	
Typical triggering threshold at I _s = 100 %	2,9 V DC		16 V DC		26 V DC	
Switching time	C/O	20 μs / 1,3 ms	20 μs / 1,3 ms		20 μs / 1,3 ms	
Leakage current	1 mA		1 mA		1 mA	
OUTPUT						
Max. voltage / Max. current	58 V / 100 mA		58 V / 100 mA		58 V / 100 mA	
Residual voltage max. I and rated U						
standard U	1 V DC		1 V DC		1 V DC	
max.	1,3 V DC		1,3 V DC		1,3 V DC	
Frequency on inductive load	See Note 1		See Note 1		See Note 1	
Input / Output isolation	2,5 kV		2,5 kV		2,5 kV	
TEMPERATURE						
Storage	- 30°C to + 80°C		- 30°C to + 80°C		- 30°C to + 80°C	
Operating	- 20°C to + 60°C		- 20°C to + 60°C		- 20°C to + 60°C	

MOS output optocoupler plugs

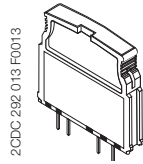

1 A output optocoupler 5 V DC

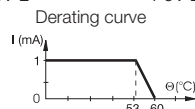
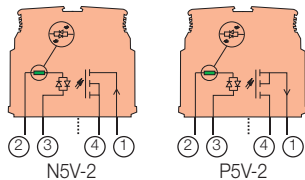

1 A output optocoupler 24 V DC

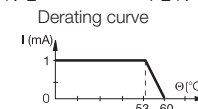
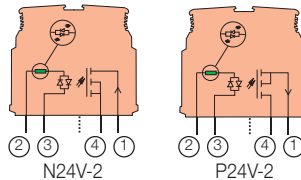

Note 1 :

$$F_{max} = (1 - 0,007 \times U_s) / (L \times I_s^2)$$

or

$$F_{max} = (1 - 0,007 \times U_s) / (P \times \frac{L}{R})$$

U_s = Output voltage supply
 I_s = Output current
 L = Inductive load
 P = Load power
 R = Load resistance

Part numbers	Type	P/N	Type	P/N
	BNMS N5V-2	1SNA031816R0400	BNMS N24V-2	1SNA031817R0500
	BNMS P5V-2	1SNA031818R1600	BNMS P24V-2	1SNA031819R1700
Characteristics				
INPUT				
Voltage	4,5 V to 5,5 V DC		20,4 V to 28,8 V DC	
Max. current	12,5 mA		6,7 mA	
Typical triggering threshold at I _s =100%	3,5 V DC		10 V DC	
Switching time	C/O	20 μs / 250 μs	50 μs / 350 μs	
Leakage current	1 mA		1 mA	
OUTPUT				
Max. voltage / Max. current	58 V / See graphs		58 V / See graphs	
Residual voltage max. I and rated U				
standard U	1 V DC		1 V DC	
max.	1,3 V DC		1,3 V DC	
Frequency on inductive load	See Note 1		See Note 1	
Input / Output isolation	2,5 kV		2,5 kV	
TEMPERATURE				
Storage	- 30°C to + 80°C		- 30°C to + 80°C	
Operating	- 20°C to + 60°C		- 20°C to + 60°C	

MOS output optocoupler plug

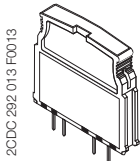

2CDC 292 013 F0013

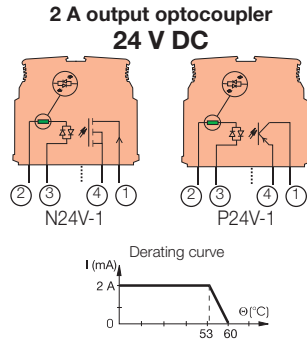
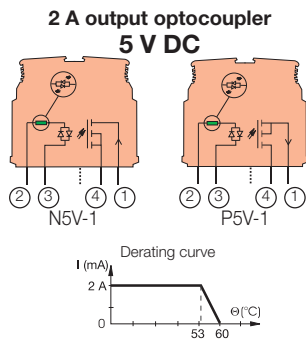

Note 2 :

$$F_{max} = (1 - 0,012 \times U_s) / (L \times I_s^2)$$

or

$$F_{max} = (1 - 0,012 \times U_s) / (P \times \frac{1}{R})$$

U_s = Output voltage supply
I_s = Output current
L = Inductive load
P = Load power
R = Load resistance

Part numbers	Type	P/N	Type	P/N
	BNMS N5V-1	1SNA031812R0000	BNMS N24V-1	1SNA031813R0100
	BNMS P5V-1	1SNA031814R0200	BNMS P24V-1	1SNA031815R0300
Characteristics				
INPUT				
Voltage	4,5 V to 5,5 V DC		20,4 V to 28,8 V DC	
Max. current	12,5 mA		6,7 mA	
Typical triggering threshold	3,5 V DC		10 V DC	
Switching time	C/O	20 μs / 250 μs	50 μs / 350 μs	
Leakage current	1 mA		1 mA	
OUTPUT				
Max. voltage / Max. current	30 V DC / See graphs		30 V / See graphs	
Residual voltage max. I and rated U				
standard U	1 V DC		1 V DC	
max.	1,3 V DC		1,3 V DC	
Frequency on inductive load	See Note 2		See Note 2	
Input / Output isolation	2,5 kV		2,5 kV	
TEMPERATURE				
Storage	- 30°C to + 80°C		- 30°C to + 80°C	
Operating	- 20°C to + 60°C		- 20°C to + 60°C	

Triac output optocoupler plug

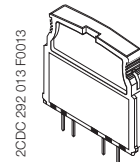

2CDC 292 013 F0013

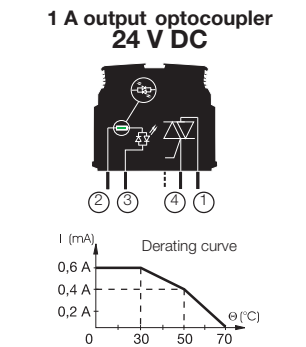

Part numbers	Type	P/N
	BNMS A24V-4	1SNA031839R1300
Characteristics		
INPUT		
Voltage	20,4 V to 28,8 V DC	
Max. current	3,8 mA	
Typical triggering threshold	10 V DC	
Switching time	C/O	9,5 ms / 12 ms
Leakage current		
OUTPUT		
Max. voltage / Max. current	24 V to 253 V AC / See derating curve	
Residual voltage max. I and rated U		
standard U	1 V AC	
max.	1,3 V AC	
Input / Output isolation	2,5 kV	
TEMPERATURE		
Storage	- 30°C to + 80°C	
Operating	- 20°C to + 70°C	

Relay plugs

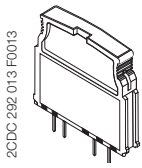

2CDC 292 013 F0013

1 SPDT relay

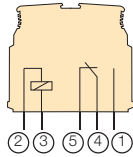

R24V-1

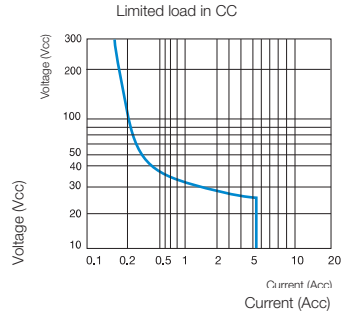
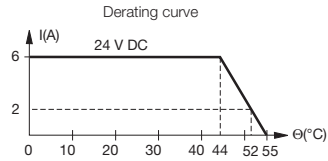

	DC12	AC12	DC13	AC15
24 V	6 A	6 A	1 A	3 A
110/120 V	0,3 A	6 A	0,2 A	3 A
220/230 V	0,2 A	6 A	0,1 A	3 A

Part numbers	Type	P/N
	BNMS R24V-1	1SNA031820R1400
	BNMS R24V-2	1SNA031847R1300

Characteristics	BNMS R24V-1	BNMS R24V-2
COIL		
Voltage	20,4 V to 28,8 V DC	
Current max.	7 mA	
Trip voltage	1,2 V	
CONTACT		
Type	1 SPDT	
Voltage mini. / max.	12 V / 250 V	5 V / 250 V
Switching current mini. / max.	10 mA / 6 A	1 mA / 6 A
Switching current AC1 mini. / max.	0,6 W / 1500 VA (resistance)	0,05 W / 1500 VA (resistance)
Switching current DC1 mini. / max.	0,6 W / 140 W	0,05 W / 140 W
Number of operations on load	10 ⁸ operations for AC15	
Number of operations off load	10x10 ⁶ operations	
Operating speed C/O	6 ms / 8 ms	
Bounce	1,5 ms	
Isolation Coil / Contact	4 kV	
Resistance to shock waves Coil / Contact	4 kV	
Isolation Contact / Contact	1 kV	
TEMPERATURE		
Storage	- 40°C to + 80°C	
Operating	- 20°C to + 55°C	

5

Analogical plugs

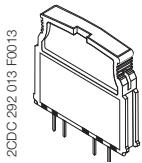

2CDC 292 013 F0013

Current / Voltage Converter

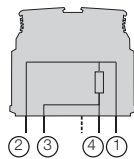

Plug with 250 Ω accuracy resistance for analogical signals.

Current / Voltage Converter

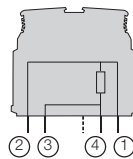

Plug with 500 Ω accuracy resistance for analogical signals.

Part numbers	Type	P/N	Type	P/N
	BNMS CA I/U-250	1SNA031832R0400	BNMS CA I/U-500	1SNA031833R0500

Characteristics	250 Ω	500 Ω
Resistance	250 Ω	500 Ω
Power	0,35 W	0,35 W
Accuracy	0,1 %	0,1 %
Stability	25 ppm	25 ppm

Fuse and strap plugs

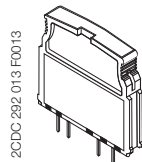

2CDC 292 013 F0013

Output fuse plug

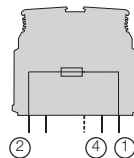

Input fuse plug

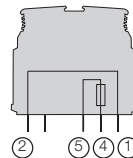

Strap plug

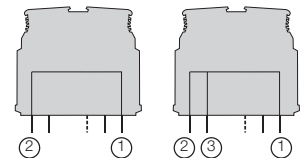

Part numbers	Type	P/N	Type	P/N	Type	P/N
	BNMS F125mA-1	125 V / 125 mA	1SNA031821R0100	BNMS F125mA-3	125 V / 125 mA	1SNA031827R0700
	BNMS F500mA-1	125 V / 500 mA	1SNA031838R1200	BNMS F125mA-4	250 V / 125 mA	1SNA031828R1000
	BNMS F2A-1	125 V / 2 A	1SNA031822R0200			
	BNMS F5A-1	125 V / 5 A	1SNA031823R0300			
	BNMS F125mA-2	250 V / 125 mA	1SNA031824R0400			
	BNMS F2A-2	250 V / 2 A	1SNA031825R0500			
	BNMS F5A-2	250 V / 5 A	1SNA031826R0600			
					BNMS ST1	1SNA031829R1100
					BNMS ST2	1SNA031830R1600



BADL



BAM2

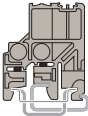

BAMH



BADH



PR30

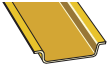

PR3.Z2

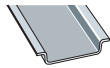

PR3.G2



PR5



PR4



FC2

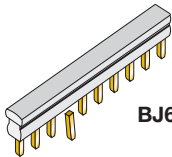

BJ612-...

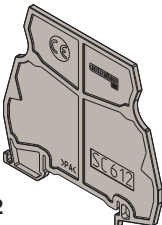

SC612

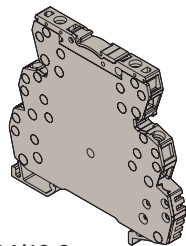

D4/12-3...

End stops

The end stops are mounted at the extremity of the terminal board assembly, giving additional support to the terminal blocks as markers. For various types of marking, refer to the marker section.

Description	Type	Order P/N	Packaging Weight kg	
End stop DIN 3	grey V0	BADL 9 mm	1SNA399903R0200	50
End stop with screws DIN 3	grey V0	BAM2 V0 10 mm	1SNA399967R0100	50
	grey V2	BAM2 10 mm	1SNA206351R1600	50
	beige V0	BAM2 V0 10 mm	1SNA296351R0000	50
	High end stop with screws DIN 1 and DIN 3	grey	BAMH 9,1 mm	1SNA114836R0000
High end stop with screws DIN 3	beige V0	BAMH V0 9,1 mm	1SNA194836R0100	50
	grey	BADH 12 mm	1SNA116900R2700	50

Mounting rails

Symmetrical zinc bichromate plated steel prepunched rail	PR30 2 m	1SNA173220R0500	1
Symmetrical zinc bichromate plated steel rail	PR3.Z2 2 m	1SNA174300R1700	1
White, symmetrical passivated galvanized steel rail	PR3.G2 2 m	1SNA164800R0300	1
Symmetrical zinc bichromate plated steel rail	PR5 2 m	1SNA168700R2200	1
Symmetrical zinc bichromate plated steel rail	PR4 2 m	1SNA168500R1200	1

Test devices

Test plug DIA. 2 mm	FC2	1SNA007865R2600	10
---------------------	-----	-----------------	----

Assembled jumper bar

This accessory permits electrical connection between 2 to 70 blocks with 6 mm spacing placed side by side. It can be used with screw clamp or spring clamp blocks with 6 mm or 12 mm spacing. Interconnection of blocks not placed side by side is possible if teeth of the jumper bar have been cut in front of the blocks not to be connected. These teeth can be removed using pliers. Use of separator end sections before and after the jumper bar is required to preserve IP20 protection of the assembly.

Assembled jumper bar 10 poles - 24 A	BJ612-10	1SNA290488R0100	10
Assembled jumper bar 20 poles - 24 A	BJ612-20	1SNA206754R0000	10

Separator end section

Directly mounted on the rail beside the block, it permits to identify and make electrical insulation of product groups using jumper bars. Dimensions are the same as screw clamp blocks : width 70 mm and height on rail 67,5 mm with 2 mm spacing.

Separator end section	SC612	1SNA290474R0200	10
-----------------------	-------	-----------------	----

Distribution module

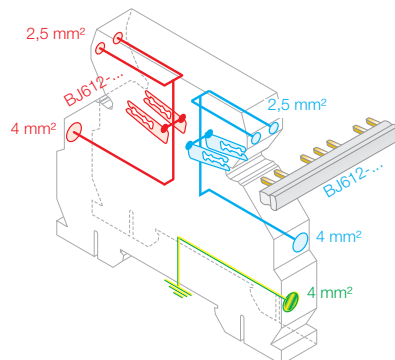

This terminal block with BJ612-... jumper bars permits 2 polarities distribution (PCL side and process side) thanks to two separate circuits, each of them including :

- one 4 mm² input,
- two 2,5 mm² outputs
- one double output for jumper bar BJ612-...

It permits also the connection of ground to the rail though a 4 mm² input.

Rated voltage : 250 VAC-DC
 Rated current : 32 A (4 mm²) - 16 A (2,5 mm²)
 Recommended torque : 0,4 - 0,6 Nm

Screw clamp distribution block sp. 12 mm	D4/12-3-3	1SNA645031R2000	5
Spring clamp distribution block sp. 12 mm	D4/12-3R-3R	1SNA645531R2200	5

Accessories

PCMS

Comb-type jumper

This accessory permits the electrical connection of 2 to 22 blocks.

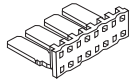

No. of poles	Grey UL94V0	Red UL94V0	Blue UL94V0	Green/Yellow UL94V0
2	1SNA205491R2300	1SNA205492R2400	1SNA205493R2500	1SNA205494R2600
3	1SNA205495R2700	1SNA205496R2800	1SNA205497R2900	1SNA205498R3000
4	1SNA205499R3100	1SNA205500R3200	1SNA205501R3300	1SNA205502R3400
5	1SNA205503R3500	1SNA205504R3600	1SNA205505R3700	1SNA205506R3800
6	1SNA205507R3900	1SNA205508R4000	1SNA205509R4100	1SNA205510R4200
7	1SNA205511R4300	1SNA205512R4400	1SNA205513R4500	1SNA205514R4600
8	1SNA205515R4700	1SNA205516R4800	1SNA205517R4900	1SNA205518R5000
9	1SNA205519R5100	1SNA205520R5200	1SNA205521R5300	1SNA205522R5400
10	1SNA205523R5500	1SNA205524R5600	1SNA205525R5700	1SNA205526R5800
11	1SNA205527R5900	1SNA205528R6000	1SNA205529R6100	1SNA205530R6200
12	1SNA205531R6300	1SNA205532R6400	1SNA205533R6500	1SNA205534R6600
13	1SNA205535R6700	1SNA205536R6800	1SNA205537R6900	1SNA205538R7000
14	1SNA205539R7100	1SNA205540R7200	1SNA205541R7300	1SNA205542R7400
15	1SNA205543R7500	1SNA205544R7600	1SNA205545R7700	1SNA205546R7800
16	1SNA205547R7900	1SNA205548R8000	1SNA205549R8100	1SNA205550R8200
17	1SNA205551R8300	1SNA205552R8400	1SNA205553R8500	1SNA205554R8600
18	1SNA205555R8700	1SNA205556R8800	1SNA205557R8900	1SNA205558R9000
19	1SNA205559R9100	1SNA205560R9200	1SNA205561R9300	1SNA205562R9400
20	1SNA205563R9500	1SNA205564R9600	1SNA205565R9700	1SNA205566R9800
21	1SNA205567R9900	1SNA205568R10000	1SNA205569R10100	1SNA205570R10200
22	1SNA205571R10300	1SNA205572R10400	1SNA205573R10500	1SNA205574R10600

PEF

Identification label holders

Designed to hold RPEV label (see opposite).

PEF * 1SNA020568R0400

* Delivered with labels.

The label holders are removable and the labels can be changed easily.

• For mounting on PCB in a 3,7 mm diameter hole.

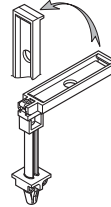

• For mounting on a PCB block in a 2 mm diameter hole (no support leg).

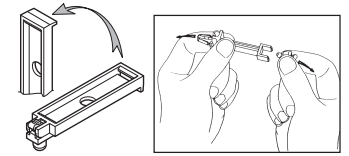

RPEV

Label for PEF 29 x 6 mm

Sheets of 99 pre-cut labels



✓ Blank RPEV 1SNA173178R0700

5

DC

Test device on screw head

This patented device is mounted on the round screwdriver opening. It is used for trouble shooting, measuring and control for monitoring and repairing an installation, on blocks without a test socket. For this, the device receives an FC2 test plug.



The DC's are differentiated by their colour :

blue for MA 2,5/5 blocks

DCB 1SNA105028R2100

PC

Comb-type jumper bar

PC EIP

This accessory can be used only on the terminal blocks with at least one compression clamp connection. It permits the electrical connection of 2 to 10 blocks.

Interconnection of non-consecutive blocks is possible by removing the teeth opposite the blocks which must not be connected. The comb-type jumper bars can be cut using pliers (or a saw) : in this case, the use of an insulating tip EIP is recommended. The comb is placed in the compression clamp before tightening the screws, above the eventual conductor.

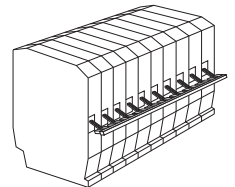

To be mounted on blocks series R900 and R910 :

Insulating tip for comb EIP 1SNA113550R2000
Comb-type jumper bar PC9 15 A 10 poles 1SNA210160R1200

BJ Jumper bar

BJS Jumper bar not assembled

To connect terminal blocks, place the metal tube into the top center hole on each terminal block to be connected.

The metal tube contacts the terminal block's internal connector bar.

The perforated bar is cut to length and placed flat along the center opening of the series of terminal blocks.

The screw is inserted into the perforated bar's hole which is located directly above the blocks being connected. The screw goes through the threaded metal tube and is screwed into the terminal block's internal connector bar. This completes the electrical connection to the perforated bar and connects the block.

To be mounted on blocks series R910 :

Screw + washer + post EV6D 1SNA168400R1600
Perforated jumper bar BJS9 32 A 8 poles 1SNA177583R1200
BJS9 32 A 16 poles 1SNA177584R1300

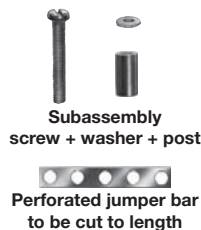

IDC jumper

(insulation displacement jumper)

Characteristics

Wire size mm ² / AWG	Rigid Flexible	IEC NFC VDE		CSA
		2,5 mm ²	14 AWG	
Voltage	V	600	600	
Current	A	26	15	
Rated wire size	mm ² / AWG	2,5 mm ²	14 AWG	
Working temperature	°C	-55°C -> +110°C		
Protection		IP20 / NEMA1		

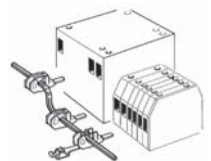
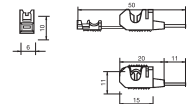

Quick-jump lets you interconnect screw clamp terminals of different sizes, levels and all manufacturers quickly and safely. Its insulation displacement technology makes it easy to use, fast, economical and does not require a special tool. Use as a jumper between relays, switches and other electronic components. ABB Quick-jump will fit any screw clamp type terminal block, from 6 mm .238" spacing and larger.

How to use : connecting Quick-jump to your terminal

- 1 - Insert ABB Quick-jump into your terminal screw clamp.
- 2 - Tighten the terminal screw.
- 3 - Guide jumper wire through the V-shaped opening in the Quick-jump.
- 4 - Secure the wire by closing the Quick-jump lever with any flat nose pliers.

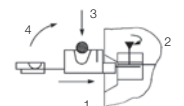

Adding a shunt in an installation :

- 1 - Insert ABB Quick-jump into your terminal screw clamp.
- 2 - Guide the terminal screw clamp into contact with the wire.
- 3 - Secure the wire by closing the Quick-jump lever with any flat nose pliers.
- 4 - Tighten the terminal screw.

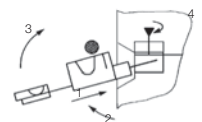

Insulation displacement jumper AD 2,5 1SNA114205R2000

RL Lengthwise marker

RLV Lengthwise marker
Width 9 mm .354"

Large area for writing.
To be snapped onto the top of blocks.

Blank marker for writing : RLV 1SNA103849R0300



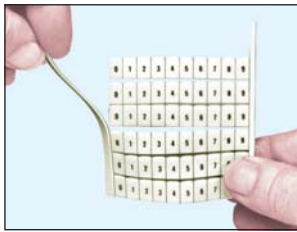

1

Remove one of the side bands of the card.

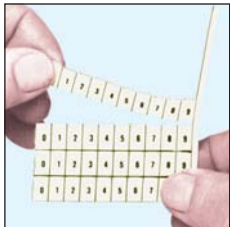

2

Separate the chosen strip from the rest of the card.

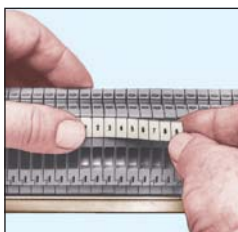

3

Press the first marker in place, hold it and slide your thumb on the rest of the strip.

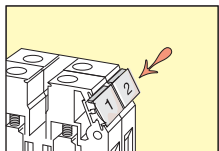

Horizontal marking

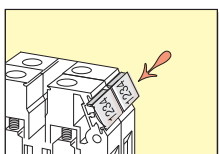

Vertical marking



Refilable box of 100 cards of 18 RC markers

Marking for Interface Modules

Selection table

Markers for modules :	RC610	RC55	RC65
R500			
R600		POSSIBLE	
R900			
R910		POSSIBLE	
R1800			

Possible mounting : **POSSIBLE**

Recommended mounting :

Impossible mounting :

Marking for terminal blocks

Standard RC marker cards

Marker sizes	<div style="display: flex; justify-content: space-around; font-size: small;"> (x) = Nb of cards in 5 mm spacing kit (x) = Nb of cards in 6 mm spacing kit (x) = Nb of cards in 6 mm spacing kit </div>		
	RC55	RC65	RC610
Blank cards	1SNA230000R1200	1SNA232000R0000	1SNA233000R0100
Horizontal marking			
10 strips from 1 to 10	1SNA230002R0000 (5)	1SNA232002R2600 (5)	1SNA233002R2700 (25)
10 strips from 11 to 20	1SNA230003R0100 (2)	1SNA232003R2700 (2)	1SNA233003R2000 (10)
10 strips from 21 to 30	1SNA230004R0200	1SNA232004R2000	1SNA233004R2100 (6)
10 strips from 31 to 40	1SNA230005R0300	1SNA232005R2100	1SNA233005R2200 (4)
10 strips from 41 to 50	1SNA230006R0400	1SNA232006R2200	1SNA233006R2300 (3)
10 strips from 51 to 60	1SNA230007R0500	1SNA232007R2300	1SNA233007R2400 (2)
10 strips from 61 to 70	1SNA230008R1600	1SNA232008R0400	1SNA233008R0500 (2)
From 1 to 100	1SNA230030R0700 (2)	1SNA232030R2500 (2)	1SNA233030R2600 (15)
From 101 to 200	1SNA230031R2400	1SNA232031R1200	1SNA233031R1300 (2)
20 times L1-L2-L3-N-PE	1SNA230131R2500	1SNA232131R1300	1SNA233131R1400 (2)
Vertical marking			
10 strips from 1 to 10	1SNA230041R0600	1SNA232041R2400	1SNA233041R2500 (5)
10 strips from 11 to 20	1SNA230042R0700	1SNA232042R2500	1SNA233042R2600 (3)
10 strips from 21 to 30	1SNA230043R0000	1SNA232043R2600	1SNA233043R2700 (2)
10 strips from 31 to 40	1SNA230044R0100	1SNA232044R2700	1SNA233044R2800 (2)
From 1 to 100	1SNA230060R1500	1SNA232060R0300	1SNA233060R0400 (6)

Marking kit RC 5 mm spacing or 6 mm spacing

Box with 100 cards with 18 various part numbers (see table next page)

Description	Type	Order P/N	Packaging	Weight kg
Box with 100 cards RC 5 mm spacing		1SNA400085R2700	1	
Refill for box RC 5 mm		1SNA400145R0700	1	
Box with 100 cards RC 6 mm spacing		1SNA400084R2600	1	
Refill for box RC 6 mm		1SNA400144R0600	1	